

This present document and its contents are confidential, and are the exclusive intellectual and / or industrial property of INGETEAM S.A., in addition to any technology, design, invention, work, process, know-how, calculation, manual, method, solution, idea, improvement, drawing, diagram, modification, contribution and, in short, any associated information or documentation involving industrial or intellectual property developed or supplied by INGETEAM S.A., on the occasion of the quote, order execution or incorporated into the design or operation of the supply. The recipient may not use such property in his favour or in that of a third party for purposes other than the fulfillment of the order and the operation and maintenance of the supply, without the prior written consent of INGETEAM S.A. It is strictly forbidden to totally or partially reproduce this document and to misuse it and / or to show it to third parties. The infringing parties shall be required to pay the corresponding compensation for damages and any other legal or criminal responsibilities the infringement may give rise to.

OVERALL DIMENSIONS

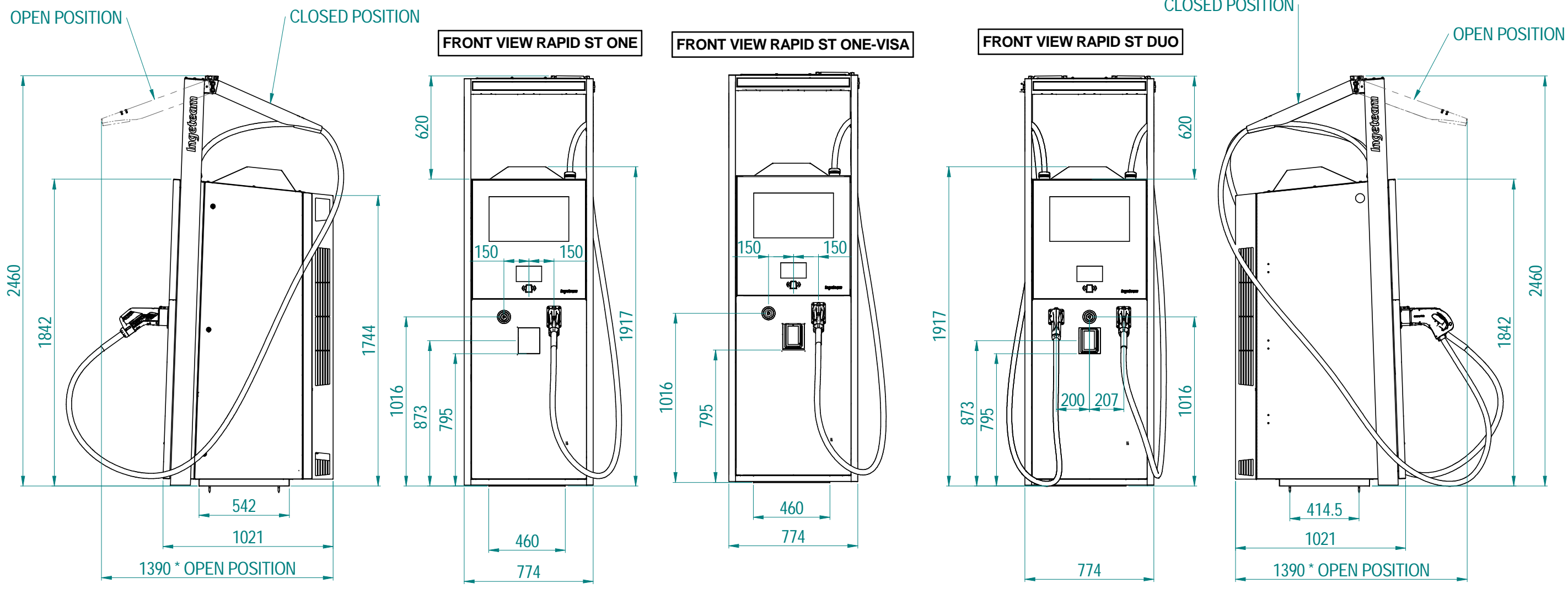

SHEET 1: OUTSIDE VIEWS
 SHEET 2: OVERALL DIMENSIONS
 SHEET 3: PACKAGING DIMENSIONS
 SHEET 4: FIXING AREA

DUO VISA kits and VISA-ready kit are added		06/03/2024	
Revision Description			Date
Designation		Scale	DIN
OVERALL DIMENSIONS		S:N	A3
General tolerances EN 22768 mK	Soldered parts EN ISO 13920 BF	Dimensions in mm	Code
Moulded parts ISO 8062	Surfaces ISO 1302	Ingeteam	Rev.
Shape and position tolerances EN ISO 1101			400031010
			E 2 4