

This present document and its contents are confidential, and are the exclusive intellectual property of INGETEAM S.A. in addition to any technology, design, invention, work, process, know-how, calculation, manual, method, solution, idea, improvement, drawing, diagram, modification, contribution and, in short, any associated information or documentation involving industrial or intellectual property developed or supplied by INGETEAM S.A. on the occasion of the quote, order execution or incorporated into the design or operation of the supply. The recipient may not use such property in his favour or in that of a third party for purposes other than the fulfilment of the order and the operation and maintenance of the supply, without the prior written consent of INGETEAM S.A. It is strictly forbidden to totally or partially reproduce this document and to misuse it and / or to show it to third parties. The infringing parties shall be required to pay the corresponding compensation for damages and any other legal or criminal responsibilities the infringement may give rise to.

# RAPID 120/180 TRIO

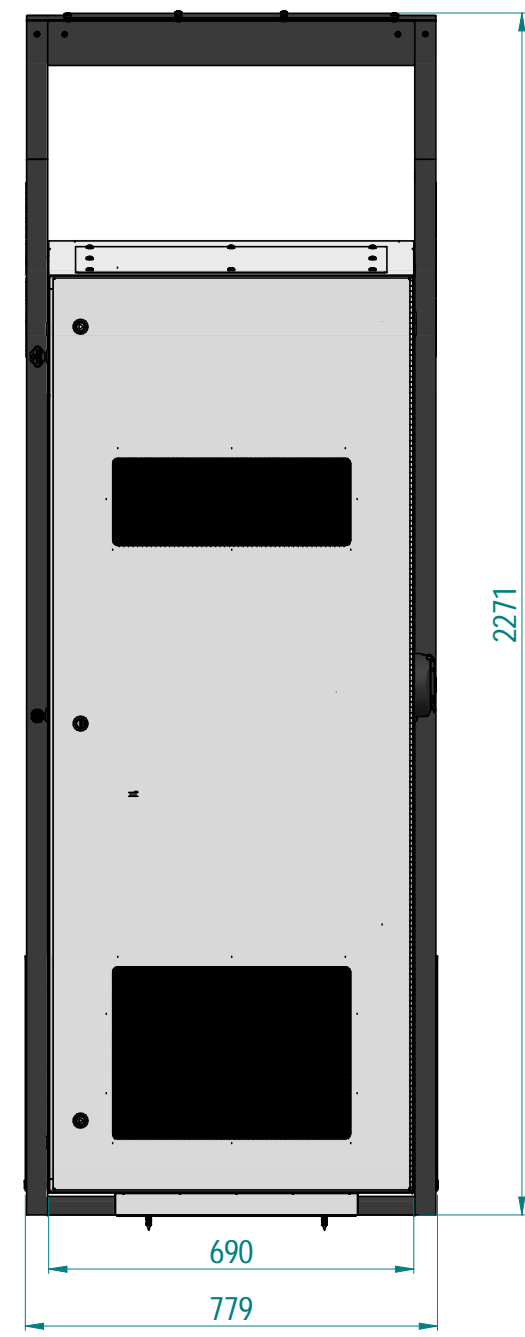
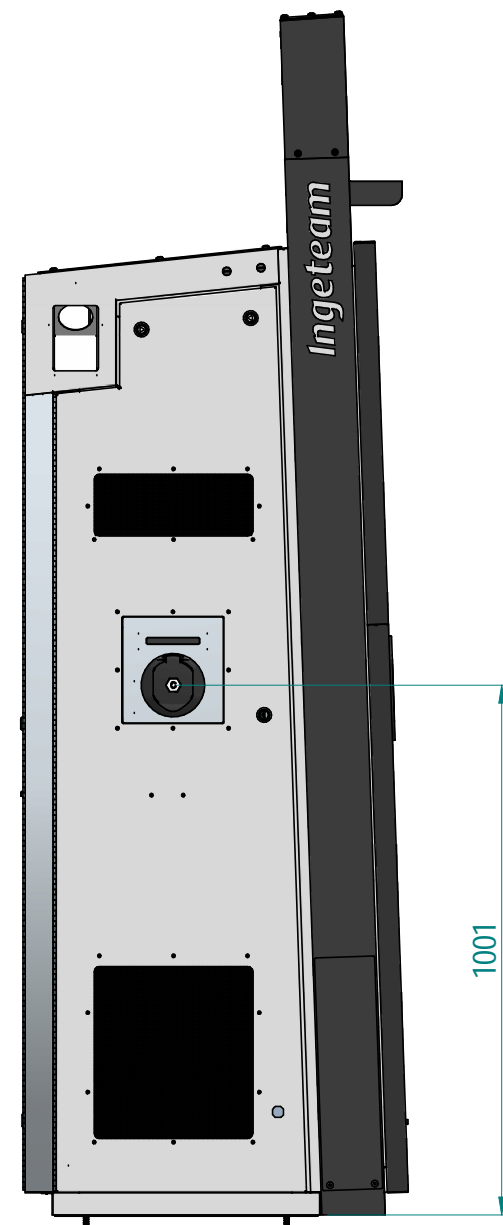
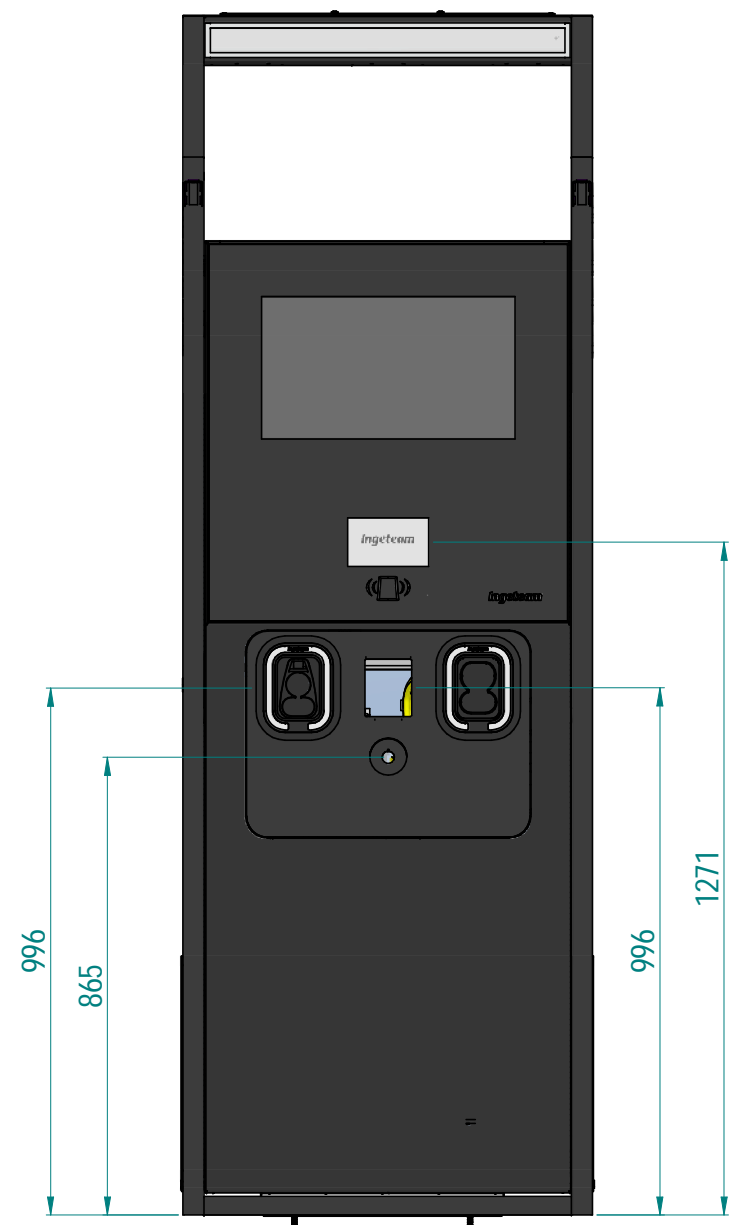
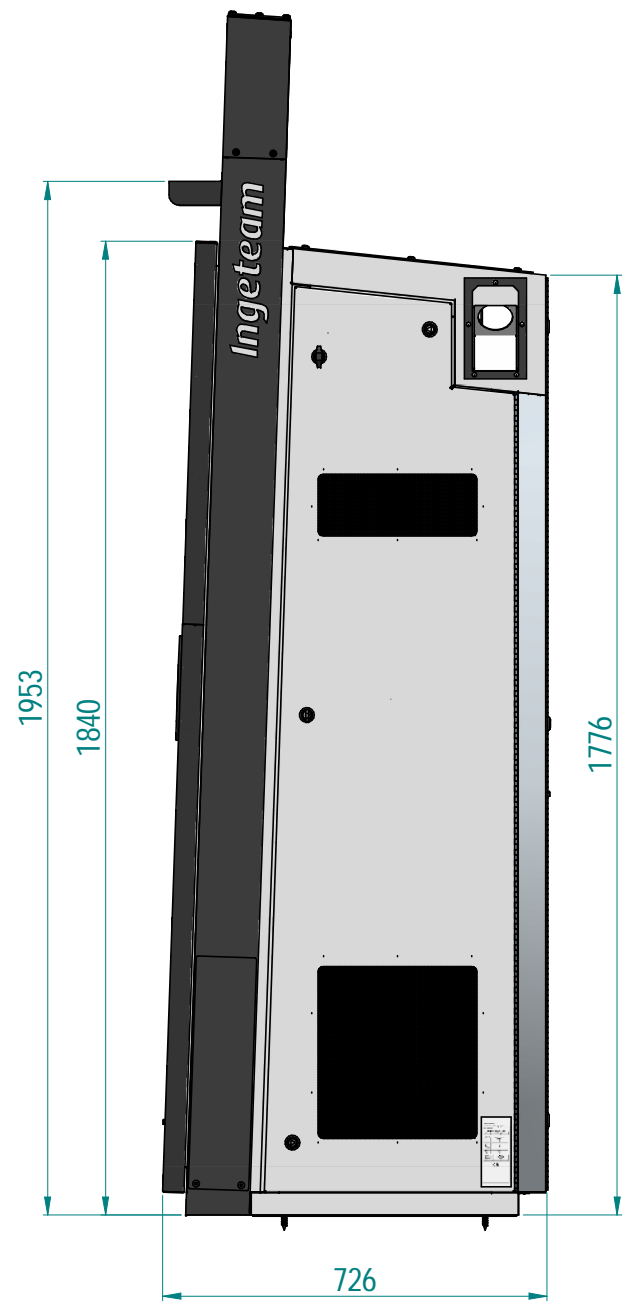

|  |  |  |  |            |                  |
|--|--|--|--|------------|------------------|
|  |  |  |  | 02/08/2023 |                  |
| Revision Description   |  |  |  |            | Date             |
| Designation  |  |  |  |            | Scale            |
| GENERAL DIMENSIONS RAPID 180   |  |  |  |            | DIN              |
|  |  |  |  |            | A3               |
| General tolerances<br>EN 22768 mK<br>Moulded parts<br>ISO 8062<br>Shape and position tolerances<br>EN ISO 1101 |  |  |  |            | Dimensions in mm |
| Soldered parts<br>EN ISO 13920 BF<br>Surfaces<br>ISO 1302  |  |  |  |            | Code             |
| <b>Ingeteam</b>  |  |  |  |            | 400047180        |
|  |  |  |  |            | Rev.             |
|  |  |  |  |            | A                |
|  |  |  |  |            | Sheet            |
|  |  |  |  |            | 5   8            |